



Modular ice maker - Scale system Daily production up to 1560 kg

Hotel	████████████████████
Restaurant	████████████████████
Fast food	████████████████████
Bar	████████████████████
Disco	████████████████████
Fish market	████████████████████
Supermarket	████████████████████
Medical & SPA	████████████████████
Industry	████████████████████

► Position n°



► Features & Plus

- Sub-cooled scale ice 99% dry
- 1l (water) - 1kg (ice) - only Air cooled
- AISI 304 SS Scotch Brite finish
- Tropical class +43°C
- Specific volume 1 m³ = 430 kg of ice
- Vertical fixed "no leak" evaporator
- Anticorodal alloy evaporator
- Removable and cleanable air filter
- Cleanable antiscaling filter
- Air or water cooling system
- FDA approved - ABS plastic components
- Easy cleanable internal rounded surfaces
- RoHS Free
- Electromechanical operation
- Automatic water charge
- Standard and special voltages
- Frame in INOX



Vertical fixed "no leak" evaporator



Removable and cleanable air filter



Cleanable antiscaling filter



Frame in INOX

► Usable Bins

- Bin 550V DS
- Double Roller Bin 500

► Prod. 24h

Air temp.	Water temp.		Kg	Lbs	
	10° C	50° F			7° C
10° C	50° F	7° C	45° F	1560	3439
21° C	70° F	15° C	60° F	1500	3307

2 Years Warranty
subject to limitations

► Certifications available for this model





Modular ice maker - Scale system Daily production up to 1560 kg

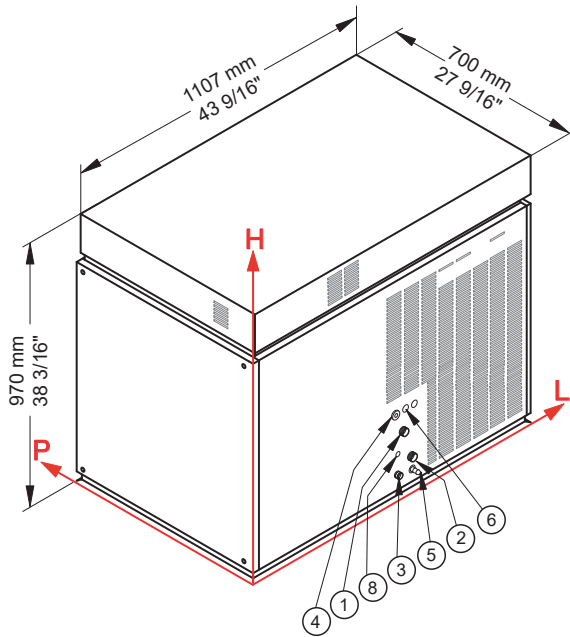

▶ Working conditions

- Location: **Indoor**

	Min	Max
Ambient temperature	+10° C / +50° F	+43° C / 110° F
Water temperature	+3° C / +37° F	+32° C / +90° F
Voltage	-10%	+10%
Water inlet pressure	1bar (14 psi)	6bar (84 psi)

▶ Performances

	Air temperature	Water temperature					
		7° C	45° F	15° C	60° F	21° C	70° F
	10° C	1560 kg					
	50° F		3439 lbs				
	21° C			1500 kg			
	70° F				3307 lbs		
	32° C					1200 kg	
	90° F						2646 lbs

▶ Connections

All measures are referred to the down-left corner (L-H-Ø)

- ① Water in.: 563 mm / 22 3/16" - 192 mm / 7 9/16" - 3/4"
- ② Cond. water in.: 563 mm / 22 3/16" - 125 mm / 4 15/16" - 3/4"
- ③ Water out.: 528 mm / 20 13/16" - 65 mm / 2 9/16" - 24 mm / 15/16"
- ④ Electrical connections: 532 mm / 20 15/16" - 262 mm / 10 5/16"
- ⑤ Cond. water out.: 573 mm / 22 9/16" - 65 mm / 2 6/16" - 12 mm / 8/16"
- ⑥ Remote connections.: 574 mm / 22 10/16" - 262 mm / 10 5/16"
- ⑧ Connection to feed pump: 515 mm / 20 5/16" - 159 mm / 10 5/16"
- ② ③ Only for water cooling systems

▶ Technical information

Production in 24h	1500 kg / 3307 lbs	Sizes (L-P-H mm)	1107 - 700 - 970
Cooling system	A - W	(L-P-H in)	43 9/16 - 27 9/16 - 38 3/16
Refrigerant	R452A	Sizes with pack (L-P-H mm)	1210 - 800 - 1185
Standard voltage	400-415 V ~ 3N 50 Hz	(L-P-H in)	47 10/16 - 31 8/16 - 46 10/16
Electrical consumption	6000 W	Net weight	306 kg / 675 lbs
Fuse	32 A	Gross weight	342 kg / 754 lbs
Water consumption	A: 1 l/kg - 12,0 gal/100 lbs W: 7 l/kg - 83,9 gal/100 lbs	Finish	AISI 304 stainless steel, scotch brite

All the technical information need to be considered at the following conditions:
 Ambient temperature +21° C
 Water temperature +15° C
 Electrical consumption at +21° C (standard voltage)

Models and specifications are subject to change without notice

Rev. 03 - Issued January 2025

