



Ice Cube

CB 246 HC

B-Qube



Self-contained ice maker - Sprayer system Daily production up to 30 kg

| | | | |
|---------------|-----------------|---------------|-----------------|
| Hotel | ● ● ● ● ● ● ● ● | Hotel | ● ● ● ● ● ● ● ● |
| Restaurant | ● ● ● ● ● ● ● ● | Restaurant | ● ● ● ● ● ● ● ● |
| Fast food | ● ● ● ● ● ● ● ● | Fast food | ● ● ● ● ● ● ● ● |
| Bar | ● ● ● ● ● ● ● ● | Bar | ● ● ● ● ● ● ● ● |
| Disco | ● ● ● ● ● ● ● ● | Disco | ● ● ● ● ● ● ● ● |
| Fish markets | ● ● ● ● ● ● ● ● | Fish markets | ● ● ● ● ● ● ● ● |
| Supermarkets | ● ● ● ● ● ● ● ● | Supermarkets | ● ● ● ● ● ● ● ● |
| Medical & SPA | ● ● ● ● ● ● ● ● | Medical & SPA | ● ● ● ● ● ● ● ● |
| Industry | ● ● ● ● ● ● ● ● | Industry | ● ● ● ● ● ● ● ● |



Available Drain Pump (DP) version



Available Drain Pump (DP) version

► Features & Plus

- Compact and crystal cube
- AISI 304 SS Scotch Brite finish
- Tropical class +43°C
- Air or water cooling system
- Easy cleanable internal rounded surfaces
- HCFC-Free insulated storage
- RoHS Free
- Disappearing insulated door
- Electromechanical operation
- ON-OFF rocker switch
- Standard and special voltages
- HFC Free
- Automatic Washing system

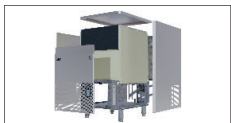

Green-Tech Design



Side openings for better ventilation



Easy cleanable internal rounded surfaces



Plug-in electrical connection

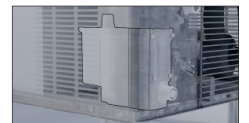

Drain Pump (DP)

2 Years Warranty subject to limitations

► Certifications available for this model



www.bremaice.it
info@bremaicegroup.it

We are Brema Group





Self-contained ice maker - Sprayer system

Daily production up to 30 kg

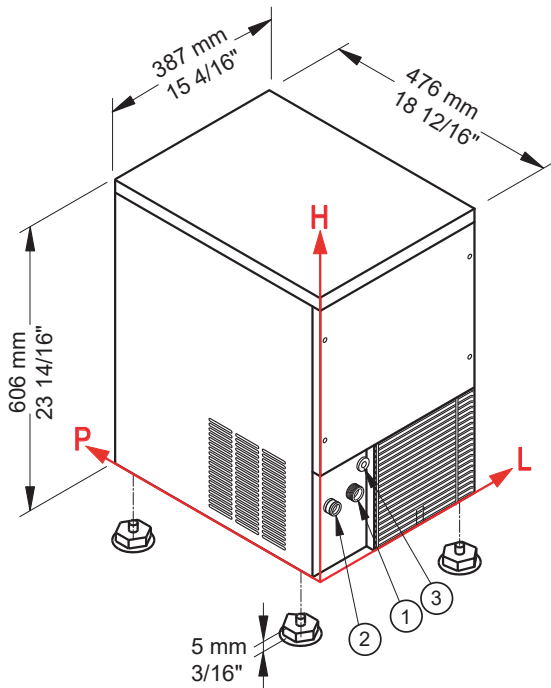

Installation

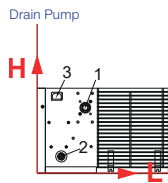

► Working conditions

- Location: **Indoor**

| | Min | Max |
|----------------------|-----------------|-----------------|
| Ambient temperature | +10° C / +50° F | +43° C / 110° F |
| Water temperature | +3° C / +37° F | +32° C / +90° F |
| Voltage | -10% | +10% |
| Water inlet pressure | 1bar (14 psi) | 6bar (84 psi) |

► Available ice cube size

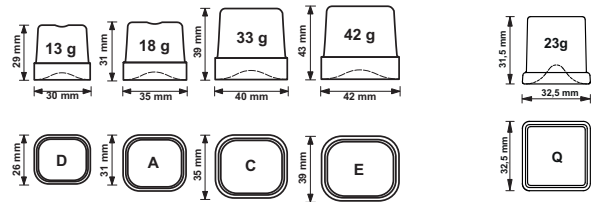

► Performances

| | | Water temperature | | | | | |
|-----------------|-------|-------------------|--------|-------|--------|-------|--------|
| | | 7° C | 45° F | 15° C | 60° F | 21° C | 70° F |
| Air temperature | 10° C | 30 kg | | | | | |
| | 50° F | | 66 lbs | | | | |
| | 21° C | | | 26 kg | | | |
| | 70° F | | | | 57 lbs | | |
| | 32° C | | | | | 21 kg | |
| | 90° F | | | | | | 46 lbs |

► Connections standard version

- ① Water in.: 130 mm / 5 2/16" - 145 mm / 5 11/16" - 3/4"
- ② Water out.: 49 mm / 1 15/16" - 140 mm / 5 8/16" - 24 mm / 15/16"
- ③ Electrical connections: 95 mm / 3 12/16" - 209 mm / 8 4/16"

Connections DP version

- 1 Water in.: 134 mm / 5 4/16" - 182 mm / 7 3/16" - 3/4"
- 2 Water out.: 66 mm / 2 10/16" - 51 mm / 2" - 24 mm / 15/16"
- 3 Electrical connection: 55 mm / 2 3/16" - 214 mm / 8 7/16"

All measures are referred to the rear bottom-left corner (L-H-Ø)

► Technical information

| | |
|---------------------------|-----------------------------------|
| Production in 24h | 26 kg / 57 lbs |
| Store capacity, up to | 6 kg / 13 lbs |
| Cooling system | A - W |
| Kind of cube | A-18g, C-33g, D-13g, E-42g, Q-23g |
| Refrigerant | R290 |
| Standard voltage | 220-240 V ~ 50 Hz |
| Average power consumption | 270 W |
| Fuse | 10 A |
| Electrical consumption | 31 kWh/100kg |

All the technical information must be considered at the following conditions:

- Sizes without feet
- Standard Cube (18 g)
- Ambient temperature +21° C
- Water temperature +15° C
- Electrical consumption at +32° C (standard voltage)
- Average power consumption at +43° C (standard voltage)

Models and specifications are subject to change without notice

| | |
|----------------------------|-------------------------------------|
| Water consumption | A: 2,5 l/kg - 30 gal/100 lbs |
| | W: 12 l/kg - 143,8 gal/100 lbs |
| Sizes (L-P-H mm) | 387 - 476 - 606 |
| (L-P-H in) | 15 4/16 - 18 12/16 - 23 14/16 |
| Sizes with pack (L-P-H mm) | 440 - 520 - 780 |
| (L-P-H in) | 17 5/16 - 20 8/16 - 30 11/16 |
| Net weight | 31 kg / 68 lbs |
| Gross weight | 37 kg / 82 lbs |
| Finish | Stainless steel, 18/8, scotch brite |

Rev. 00 - Issued February 2026



We are Brema

