



# G 510 Split

Ice Flakes



Modular ice maker - Granular system  
Daily production up to 510 kg

Hotel	██████████
Restaurant	██████████
Fast food	██████████
Bar	██████████
Disco	██████████
Fish market	██████████
Supermarket	██████████
Medical & SPA	██████████
Industry	██████████

### ► Position n°



### ► Features & Plus

- Granular ice - 80-82% dry
- 1l (water) - 1kg (ice)
- AISI 304 SS Scotch Brite finish
- Tropical class +43°C
- Specific volume 1 m<sup>3</sup> = 550 kg of ice
- AISI 304 SS evaporator
- Dust-proof water basin
- RoHS Free
- ON-OFF rocker switch
- Rotation sensor on low speed shaft
- Automatic water charge
- Standard and special voltages
- Frame in INOX



AISI 304 SS evaporator

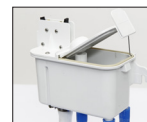

Dust-proof water basin



Rotation sensor on low speed shaft

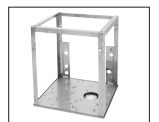

Frame in INOX

### ► Usable Bins

- Bin 240PE
- Bin 110
- Bin 200
- Bin 350
- Bin 550V DS
- Roller Bin 100
- Double Roller Bin 100
- Double Roller Bin 500
- Double Roller Bin 1200

**2 Years Warranty**  
subject to limitations

### ► Certifications available for this model



Intertek



Intertek



[www.bremagroup.it](http://www.bremagroup.it)  
[info@bremaicegroup.it](mailto:info@bremaicegroup.it)

We are Brema





Ice Flakes

# G 510 Split



Modular ice maker - Granular system  
Daily production up to 510 kg

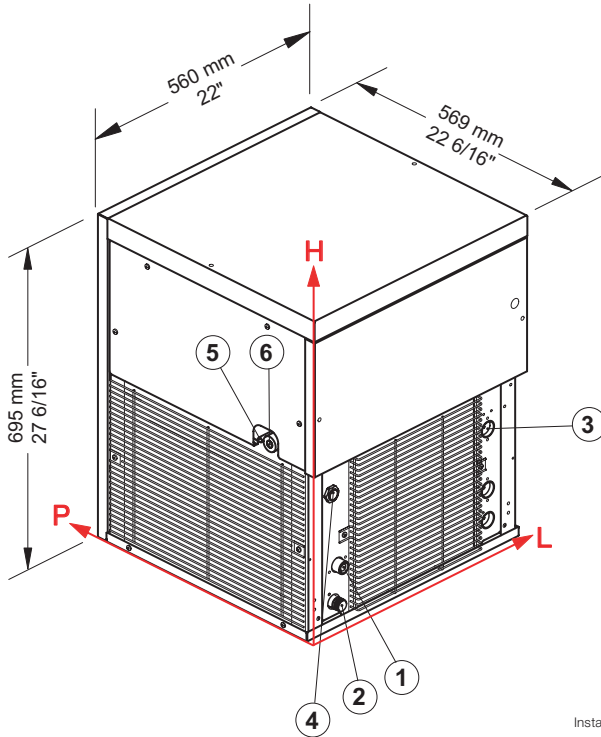

Installation



## ► Working conditions

- Location: **Indoor**

	Min	Max
Ambient temperature	+10° C / +50° F	+43° C / 110° F
Water temperature	+3° C / +37° F	+32° C / +90° F
Voltage	-10%	+10%
Water inlet pressure	1bar (14 psi)	6bar (84 psi)

## ► Connections

- ① Water inlet
- ② Water outlet
- ③ Remote connection
- ④ Electrical connection
- ⑤ Refrigerant feeding pipe
- ⑥ Outlet pipe of gaseous refrigerant

## ► Technical information

Production in 24h	510 kg / 1124 lbs
Usable refrigerant	R404A - R507 - R448A - R449A - R407F - R452A
Refrigerant capacity	2300W (evap. temp. -18° C)
Water consumption	1 l/kg - 12,0 gal/100 lbs
Standard voltage	220-240 V ~ 50 Hz
Average power consumption	175 W
Finish	AISI 304 stainless steel, scotch brite

Sizes (L-P-H mm)	560 - 569 - 695
(L-P-H in)	22 - 22 6/16 - 27 6/16
Sizes with pack (L-P-H mm)	645 - 645 - 910
(L-P-H in)	25 6/16 - 25 6/16 - 35 13/16
Net weight	67 kg / 148 lbs
Gross weight	77 kg / 170 lbs

All the technical information need to be considered at the following conditions:  
 Refrigerant capacity 2300W (evap. temp. -18° C)  
 Water temperature +15° C  
 Average power consumption at +43° C (standard voltage)

Models and specifications are subject to change without notice

Rev. 03 - Issued January 2025



[www.bremagroup.it](http://www.bremagroup.it)  
[info@bremaicegroup.it](mailto:info@bremaicegroup.it)

We are Brema

